

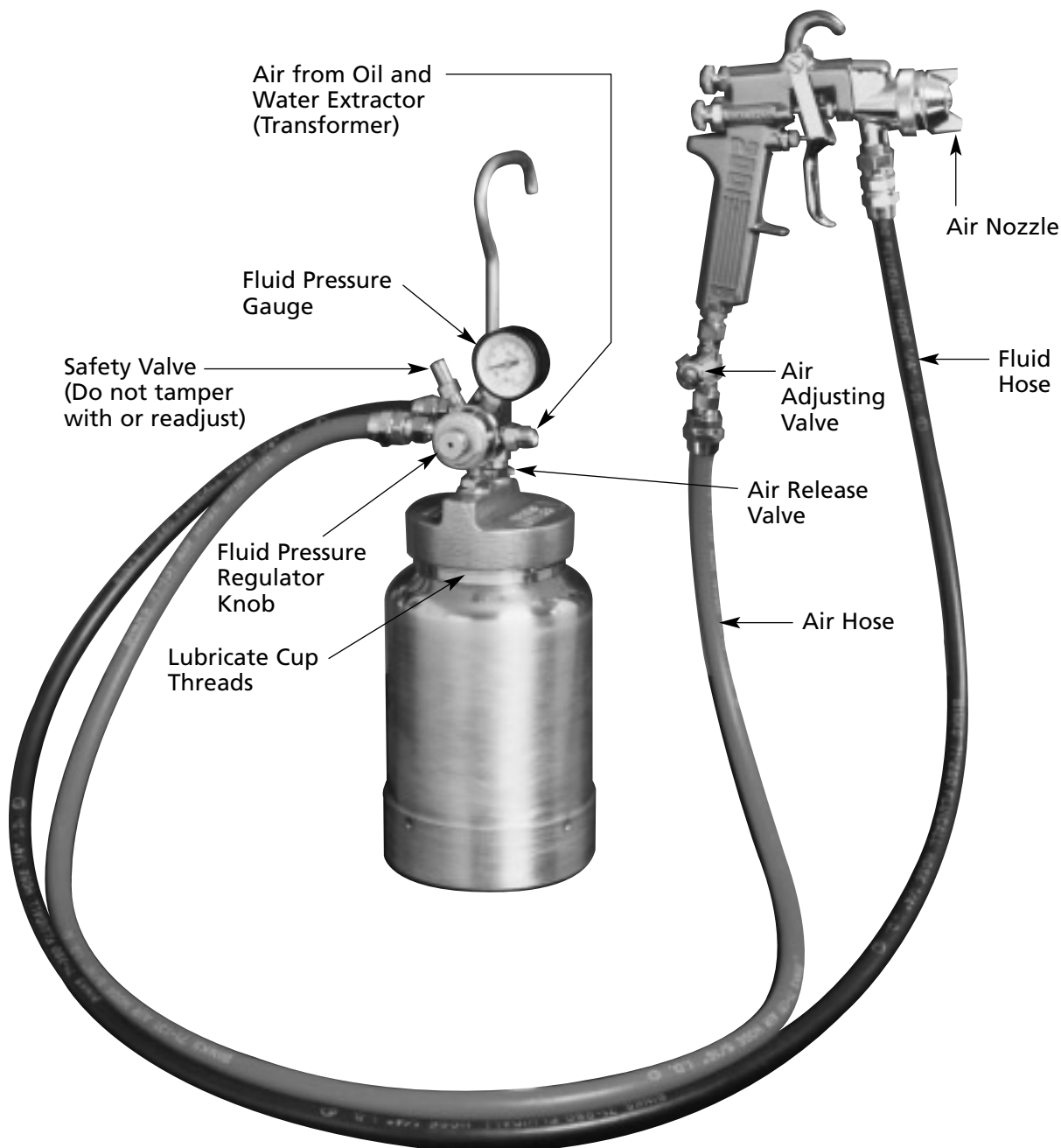

Binks Model 80-228 (2 QT.) "STEADI-GRIP" PRESSURE CONTAINER



External Mix Air Nozzle Application

OPERATION:

1. Connect hose as shown in diagram.
2. Fill cup with *strained* fluid mixed in accordance with manufacturer's recommendations on label of container.
3. Fasten cover securely.
4. Close air adjusting valve by turning clockwise.
5. Set air pressure at oil and water extractor (transformer) to between 35 and 80 PSI, depending upon atomization desired.
6. Set regulator on pressure cup to approximately 10 PSI for enamels; 5 PSI for lacquers. (Turn knob clockwise to increase pressure; to reduce pressure, turn knob counter-clockwise. Always release air in cup by momentarily opening air release valve on cover when attempting to reduce pressure.)
7. Open air adjusting valve.
8. With trigger fully pulled back, make several fast spray strokes against a flat surface. After adjustment of pressure, proper atomization will be indicated by an even distribution of finely divided paint particles.

IMPORTANT

The most efficient atomization air pressure is the lowest air pressure that will properly atomize the paint. This will minimize the overspray, deposit more paint on the surface and eliminate paint wastage.

If a faster coverage is necessary, first increase fluid pressure and then adjust atomization air pressure. If a slower coverage is more desirable, first reduce the fluid pressure and then adjust atomization air pressure. Always attempt to maintain the lowest pressures for maximum efficiency.

For ease of removing cup cover and to prevent leakage, always thoroughly grease the threads on cup.

CLEANING

1. Open air release valve on pressure cup cover.
2. Reduce pressure in cup until gauge reads zero, (turn knob counter-clockwise).
3. Loosen cup cover and set fluid tube on angle in cup.
4. Loosen air nozzle two turns, place cloth over nozzle and pull the trigger to force paint into cup.
5. Remove cover and clean cup and cover thoroughly.
6. With approximately 1/4 to 1/2 cup of clean solvent, attach cover and set fluid pressure at approximately 10 PSI.
7. Close air adjusting valve at spray gun.
8. Trigger gun and allow solvent to flow into a container until it flows clear.

9. Remove solvent, then clean air nozzle. If any dirt appears in orifice, clean with tooth pick; wire will damage nozzle. Blow nozzle and cup dry. Replace nozzle and cover loosely.

NOTE

Never allow solvent to remain in cup; solvent vapors tend to reduce service life of gasket. Separate storage of cup and cover recommended.

CAUTION

If the cup is accidentally tipped over or held at too great an angle, fluid will load up the underside of cup cover, and leak into regulator. In the event this happens, clean immediately!

Internal Mix Air Nozzle Application

OPERATION

The internal mix air nozzle accomplishes atomization by mixing the air and fluid within the air nozzle.

NOTE

The steps are the same as with the external mix nozzles, except the air and fluid pressure settings are different.

1. Close air adjusting valve by turning clockwise.
2. Set air pressure at oil and water extractor (transformer) to approximately 45 PSI.
3. Open air adjusting valve and allow air to enter the gun.
4. Set fluid pressure at 20 lbs. and adjust higher or lower until desired atomization is effected. Air pressure should be alternately adjusted.

Binks Model 80-228 (2 QT.) "STEADI-GRIP" PRESSURE CONTAINER

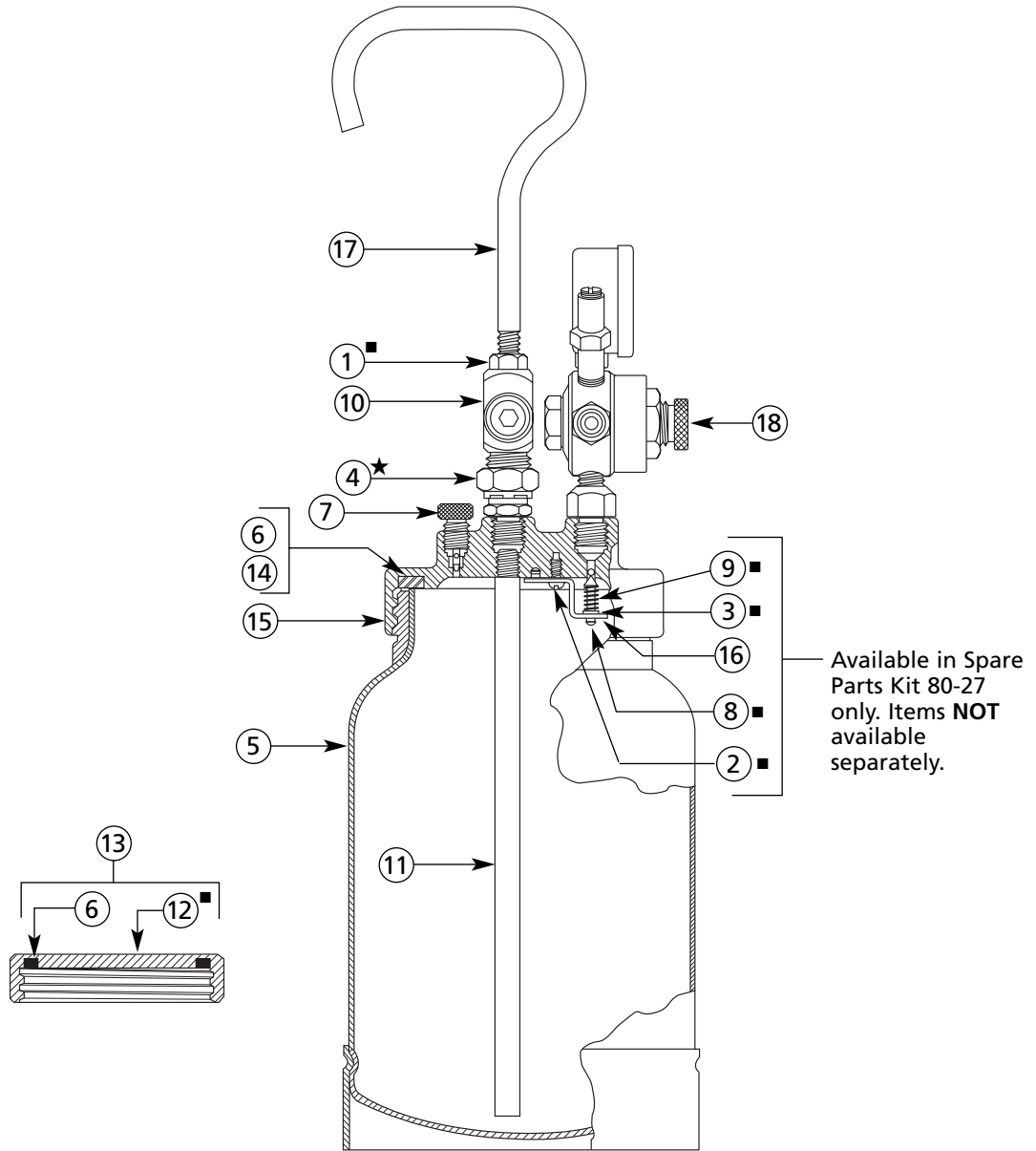

PARTS LIST

When ordering, please specify Part No.

ITEM NO.	PART NO.	DESCRIPTION	QTY.	ITEM NO.	PART NO.	DESCRIPTION	QTY.
1	20-353■	HEX JAM NUT 5/16"		10	80-33	FLUID OUTLET	1
2	20-1830-5●○	SCREW (No.6-32 x 1/4 Rd. Hd. Machine)		11	80-34	FLUID TUBE (2 Quart)	1
3	57-125-5●○	CHECK VALVE WASHER		12	80-42*■	COVER	
4	72-1022★	CENTER POST ASSEMBLY	1	13	80-43*	COVER ASSEMBLY	1
5	80-4	CUP (2 Quart)	1	14	80-45*	COVER GASKET (Leather).....	1
6	80-11-5○	COVER GASKET (Tri Seal Foam).....	1	15	80-225	CONTAINER COVER	1
7	80-12	RELIEF VALVE STEM	1	16	80-226●	CHECK VALVE BRACKET	1
8	80-25●■	CHECK VALVE		17	83-1899	HANDLE	1
9	80-26-5●○	CHECK VALVE SPRING		18	85-237▲	REGULATOR ASSEMBLY	1

* Accessories available.

● Included in Spare Parts Kit No. 80-27.

▲ Item 18 ref. Part Sheet 2417.

■ Items NOT available separately.

★ Available from Industrial Finishing distributors only.

○ Available only as 5-pack.

WARRANTY

This product is covered by Binks' 1 Year Limited Warranty.

77-1619R-10 Revisions: Updated contact information.

Binks Worldwide Sales and Service Listing: www.binks.com

ITW Industrial Finishing

Binks has authorized distributors throughout the world. For technical assistance or the distributor nearest you, see listing below.

U.S./Canada Technical Service Office:

195 Internationale Blvd., Glendale Heights, IL 60139
Toll-Free Telephone: 1-888-992-4657 (U.S.A. and Canada only)
Toll-Free Fax: 1-888-246-5732

ITW Automotive Refinishing

Binks has authorized distributors throughout the world. For equipment, parts and service, check the Yellow Pages under "Automotive Body Shop Equipment and Supplies." For technical assistance, see listing below.

U.S./Canada Customer Service Office:

1724 Indian Wood Circle, Suite J-K, Maumee, OH 43537
Toll-Free Telephone: 1-800-445-3988 (U.S.A. and Canada only)
Toll-Free Fax: 1-800-445-6643



An Illinois Tool Works Company

11/03 © 2003 Illinois Tool Works Inc. All rights reserved. Printed in U.S.A.